

# SHIFNOID WIRING DIAGRAM

## SHIFNOID NCRPM3000 RPM SWITCH with DELAY

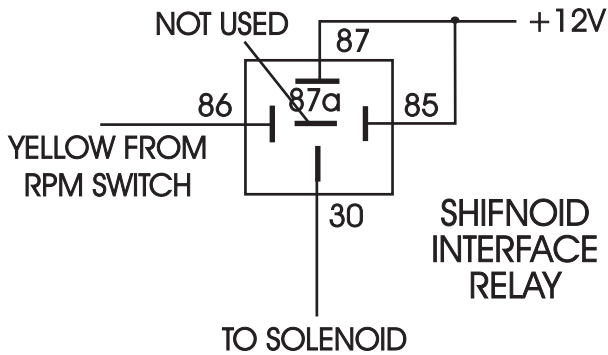

**FIGURE A**

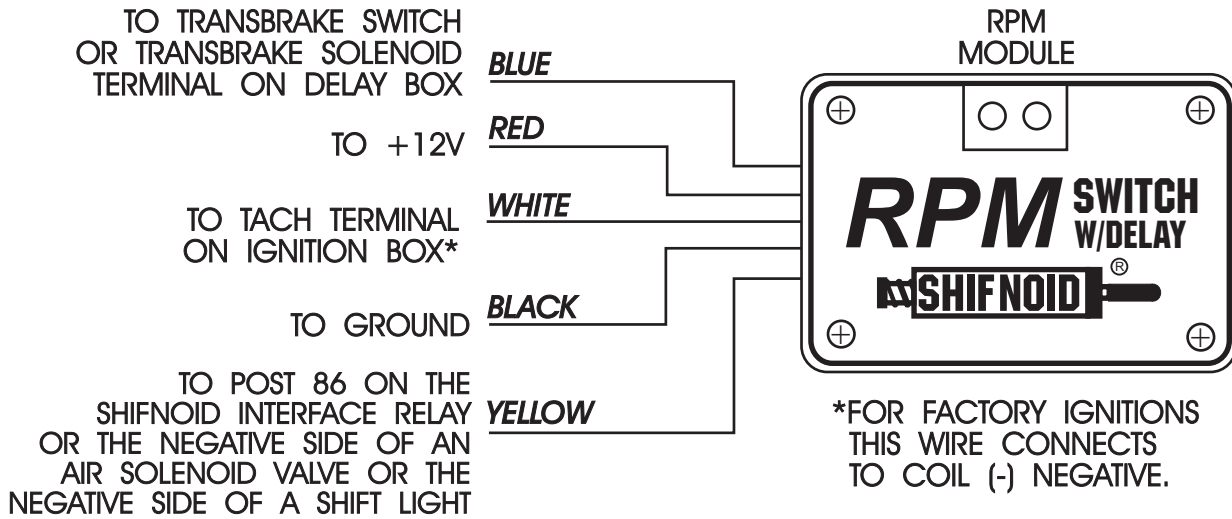
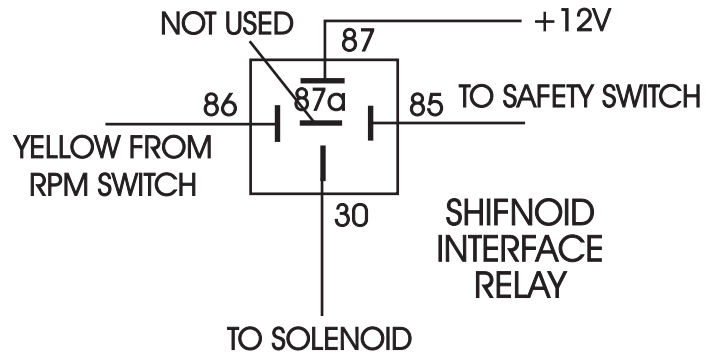

**FIGURE B**

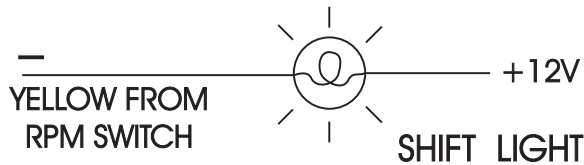

**FIGURE E**

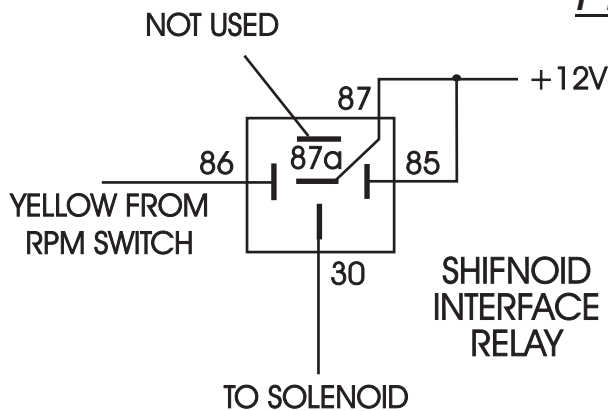

**FIGURE C**

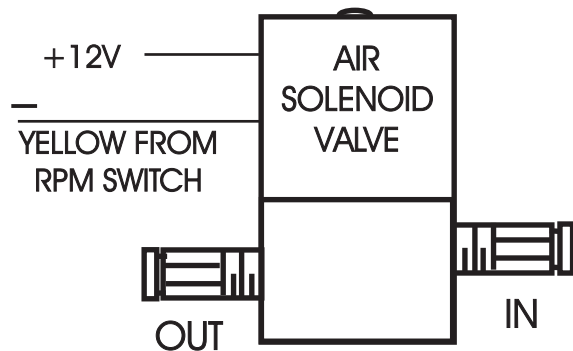

**FIGURE D**

## WIRING

Shown are five examples of how to use your RPM switch. Many combinations are possible as this switch can be used to trigger any RPM activated device. It may be necessary to use a relay on any RPM device drawing more than 1.5 amps. When using this switch to activate an air or electric shifter that requires 12 volt be applied to activate the solenoid, use FIGURE A. When using this switch to activate an electric shifter that requires 12 volts be removed to activate the solenoid, use FIGURE C. When using this switch to activate an air or electric shifter that requires 12 volt be applied to activate the solenoid only at certain times such as when a shifter is in gear, use FIGURE B. When activating a shift light with a Normally open ground, use FIGURE E. When activating an Air/CO2 solenoid with a Normally open ground, use FIGURE D. The blue wire is optional. When connecting the blue wire to your transmission brake or roll control switch you are creating a 1 second delay before your RPM switch can activate your shifter the first time. This is to reduce the possibility of a premature shift due to tire spin or converter flash. If this feature is not needed, do not connect the blue wire.

## COMMON SHIFNOID EXAMPLES

SN5000FC, SN5000RC,  
SN2000, SN5100, SN5200,  
SN5055, SN5056, SN5090                      USE FIGURE A

SN5070, SA4070, SA4075                      USE FIGURE B

SA4000, SA4055, SA4080.  
SA4080M, SA5100                              USE FIGURE D

SN1000,(Spring Loaded Solenoid)              USE FIGURE C

CAUTION: This method leaves the solenoid on at all times your RPMs are below your shift point. Then turns unit off, allowing the spring to shift your shifter.

## RF INTERFERENCE

RPM switches can be sensitive to RF interference. This problem can cause your RPM activated device to trigger at the wrong RPM, be inconsistent, or not work at all. This problem is normally most noticeable at high RPMs. If you are experiencing these types of problems please read the included information on Radio Frequency Interference.

## CAUTION

When charging your batteries, be aware that some types of battery chargers create the potential for sending excessively high voltage through your electrical system. To prevent the possibility of component damage to this switch, as well as other parts of your car, it is necessary to turn off your vehicle master switch whenever charging. A unit damaged by excessive voltage will NOT be covered under warranty.

## SHIFNOID WARRANTY

SHIFNOID warrants this product to be free from defects in material and workmanship under normal use if properly installed for a period of 90 days from the date of purchase. If found to be defective it will be repaired or replaced if returned prepaid along with proof of purchase. This shall constitute the sole remedy of purchaser and the sole liability of SHIFNOID. To the extent permitted by law, the forgoing is exclusive and in lieu of all other warranties or representations, whether expressed or implied, including any implied warranty of merchantability or fitness. In no event shall SHIFNOID be liable for special or consequential damages.

Contact your SHIFNOID retailer or CONTENDER PERFORMANCE PRODUCTS, INC.

PH: 740-927-0060 for warranty service and technical support or questions.